

Summary of Diatonic Chords (in C major)

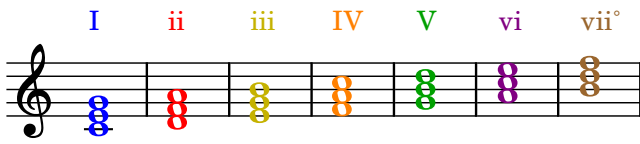

Diatonic Harmony in the Key of C major

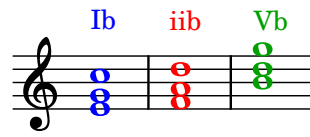

First inversion chords

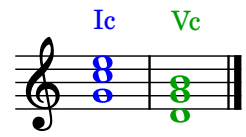

Second inversion chords

Root Position & Inverted Chord Progressions

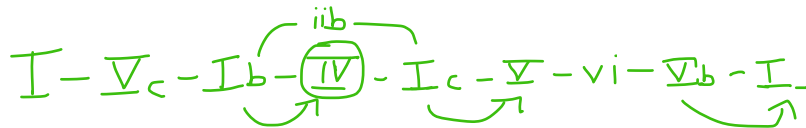
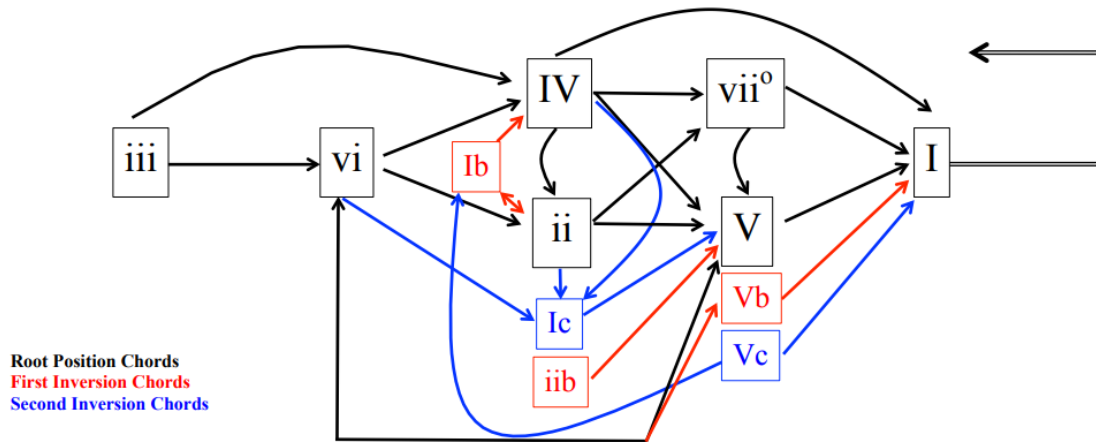

'Standard' Progressions using Circle of Fifths (Major Keys)

*only use diminished chords
in first inversion

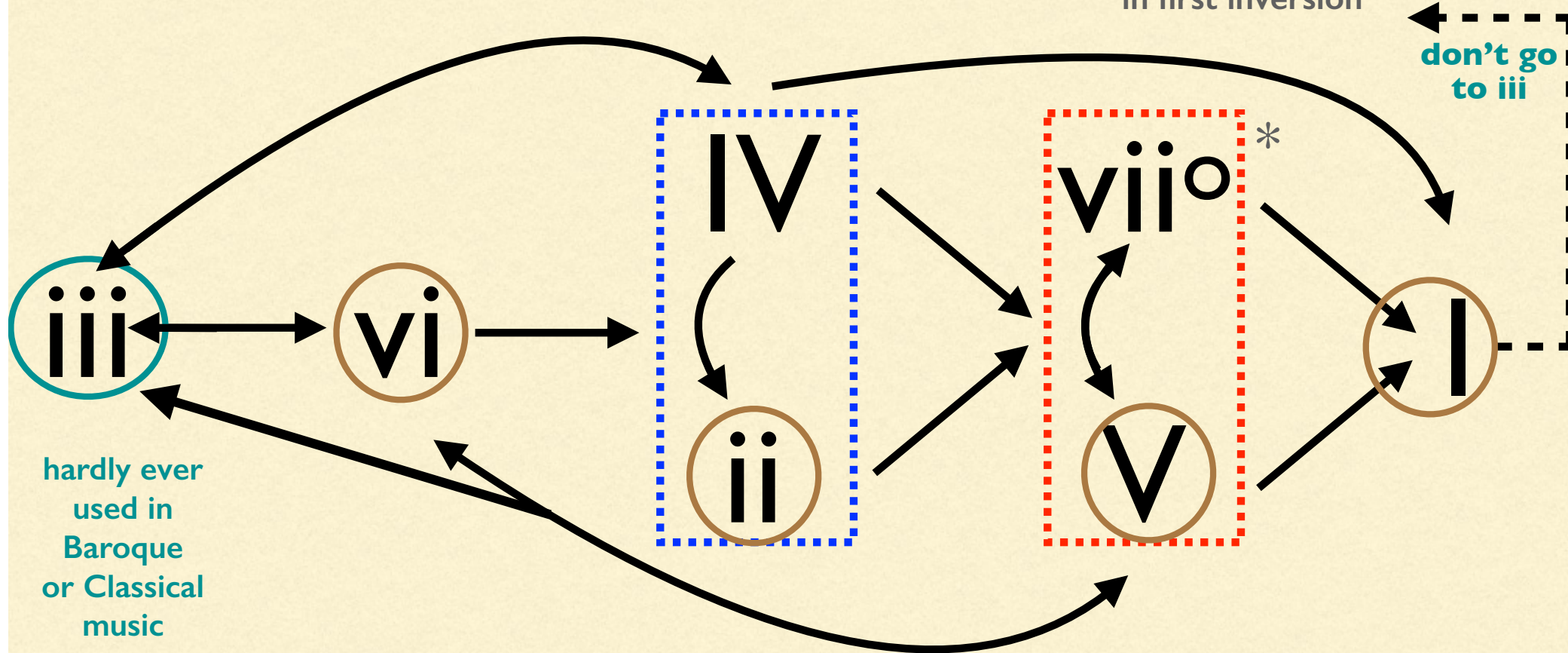

Circle of Fifths progression
is very common

Pre-Dominant
Function Group

Dominant
Function Group

'Standard' Progressions using Circle of Fifths (Minor Keys)

*only use diminished chords in first inversion

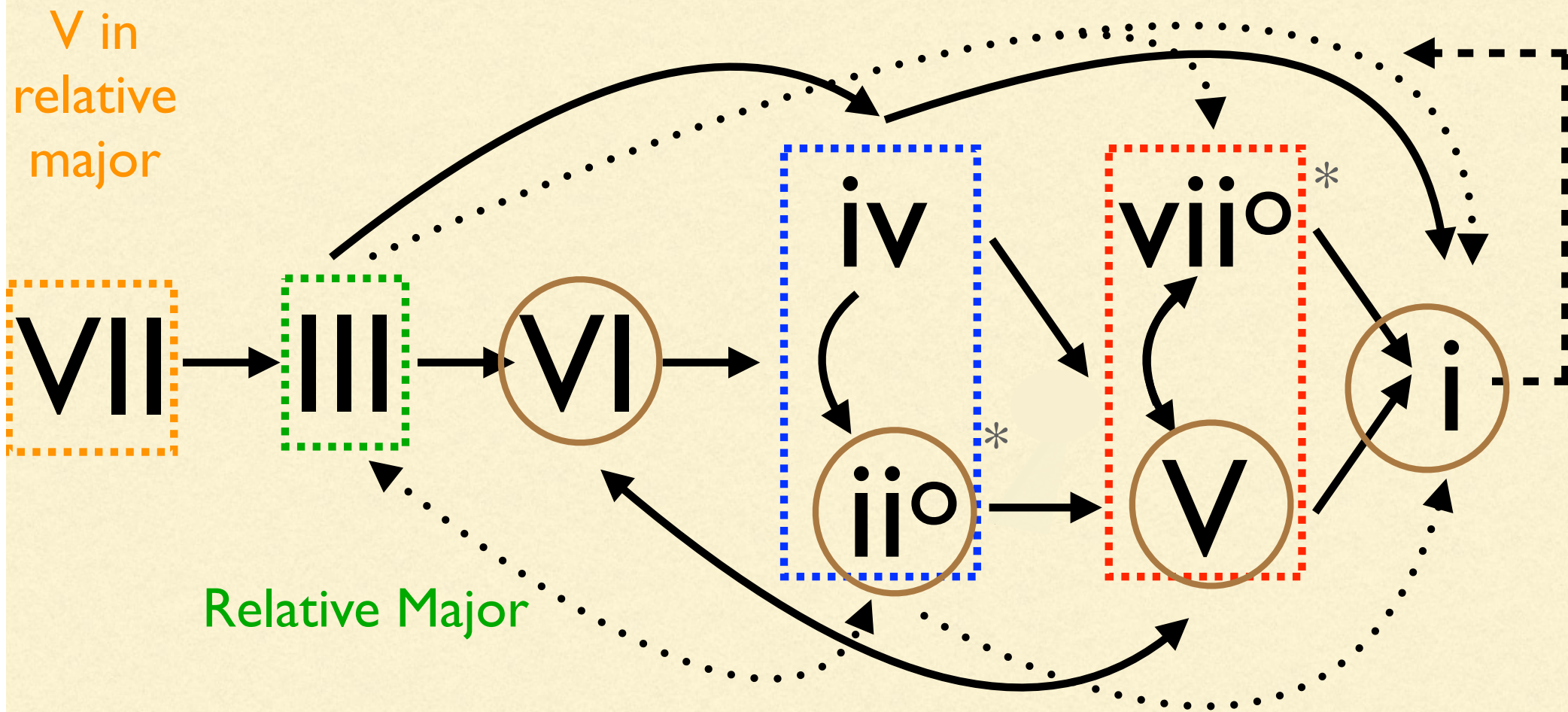

Circle of Fifths progression is very common

Pre-Dominant Function Group

Dominant Function Group